

# Rocktech Displays Limited



Module P/N: RK043HR005-CTG

Version: 1.0

Description : 4.3 inch TFT 800\*480 Pixels with LED  
Backlight and capacitive touch panel ,  
All viewing angle

TEL: 0086-755-26065260

Fax: 0086-755-26065261

E-mail: [Sales@rocktech.com.hk](mailto:Sales@rocktech.com.hk)

Web: [www.rocktech.com.hk](http://www.rocktech.com.hk)

**Revision History**

<b>Date</b>	<b>Rev.</b>	<b>Page</b>	<b>Description</b>
<b>2018-03-25</b>	<b>1.0</b>	<b>All</b>	<b>First issue</b>

# CONTENTS

- GENERAL FEATURES
- ABSOLUTE MAXIMUM RATINGS
- ELECTRICAL SPECIFICATIONS
- OPTICAL SPECIFICATIONS
- BLOCK DIAGRAM
- PIN DESCRIPTION
- TIMING CHARACTERISTICS
- OUTLINE DIMENSION
- RELIABILITY AND INSPECTION STANDARD
- PRECAUTIONS

**1. General Features**

<b>Item</b>	<b>Spec</b>	<b>Remark</b>
Display Mode	Normally Black transmissive	
Viewing Angle	Free	
Input Signals	RGB 24 bit	
Outside Dimensions	105.5(W) x67.2(H) x4.53(D)	With CTP
Active Area	95.04mm(W)×53.86 mm(H)	
Number of Pixels	800(RGB)×480	
Dot Pitch	0.1188mm(H) ×0.1122 mm(W)	
Pixel Arrangement	RGB Vertical stripes	
Drive IC	HX8264-D05+HX8664B	
CTP IC	GT911	

## 2. Absolute Maximum Ratings

The following are maximum values which, if exceeded may cause operation or damage to the unit.

ITEM	Sym.	Min.	Typ.	Max.	Unit	Remark
Power for Circuit Driving	Vdd	-0.3	-	5	V	
Backlight Forward Current	I <sub>LED</sub>	-	-	25	mA	For each LED
Storage Temperature	T <sub>ST</sub>	-30	-	80	°C	
Operating Ambient Humidity	H <sub>OP</sub>	10	-		%RH	
Operating Ambient temperature	T <sub>OP</sub>	-20	-	70	°C	

### 3. Electrical Specification

#### 3.1 Driving TFT LCD Panel

Item	Sym.	Min	Typ.	Max	Unit	Note
Power for Circuit Driving	VDD	3.0	3.3	3.6	V	
Logic Input Voltage	Low Voltage	$V_{IL}$	0	-	0.3Vdd	V
	High Voltage	$V_{IH}$	0.7Vdd	-	Vdd	V
Logic Output Voltage	Low Voltage	$V_{OL}$	-	-	GND+0.4	V
	High Voltage	$V_{OH}$	Vdd-0.4	-	-	V
Power Consumption	Black Mode	$P_b$	T.B.D	T.B.D	T.B.D	mW
	Standby Mode	$P_w$	T.B.D	T.B.D	T.B.D	mW

#### 3.2 Driving Backlight

Item	Sym.	Min	Typ.	Max	Unit	Note
Backlight driving voltage	$V_F$	15	16	17	V	
Backlight driving current	$I_F$	-	40	-	mA	
Backlight Power Consumption	$W_{BL}$	-	640	-	mW	
Life Time	-	-	30,000	-		Note 3

Note 1: (Unless specified, the ambient temperature  $T_a=25^{\circ}\text{C}$ )

Note 2: The recommended operating conditions refer to a range in which operation of this product is guaranteed. Should this range is exceeded, the operation cannot be guaranteed even if the values may be without the absolute maximum ratings.

Note 3: If LED is driven by high current, high ambient temperature & humidity condition. The life time of LED will be reduced. Operating life means brightness goes down to 50% initial brightness. Typical operating life time is estimated data.

#### 3.3 Driving CTP

Item	Value
Working Voltage	DC 2.8-3.3V
Interface	I2C
Support Touch	5 points

#### 4. Optical Specifications

Optical characteristics are determined after the unit has been 'ON' and stable for approximately 30 minutes in a dark environment at 25 °C. The values specified are at an approximate distance 500mm from the LCD surface at a viewing angle of  $\Phi$  and  $\theta$  equal to 0°.

Item	Sym.	Values			Unit	Note
		Min.	Typ.	Max.		
1) Contrast Ratio	C/R	-	800	-		FIG.1
2) Module Luminance	L	320	400	-	cd/m <sup>2</sup>	After CTP
3) Response time	Tr+Tf	-	30	-	ms	FIG.2
4) Viewing Angle	$\theta_T$	-	80	-	Degree	FIG.3
	$\theta_B$	-	80	-		
	$\theta_L$	-	80	-		
	$\theta_R$	-	80	-		
5) Chromaticity	Wx	0.274	0.316	0.358		
	Wy	0.294	0.336	0.378		
	Rx	-	-	-		
	Ry	-	-	-		
	Gx	-	-	-		
	Gy	-	-	-		
	Bx	-	-	-		
	By	-	-	-		

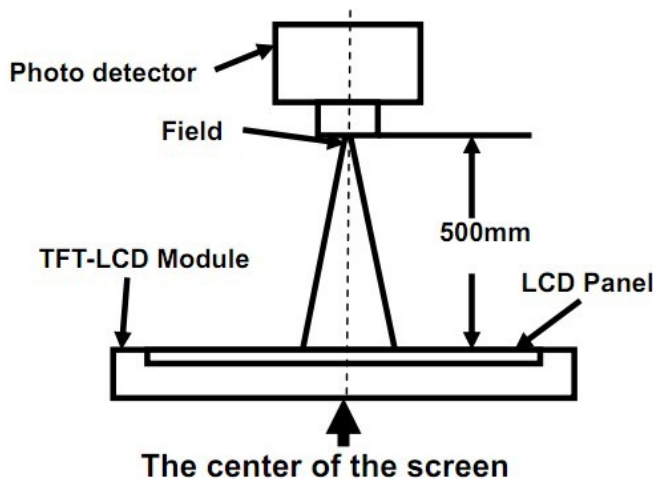
## ◆ Measurement System

Notes:

1. Contrast Ratio(CR) is defined mathematically as :  

$$\text{Contrast Ratio} = \frac{\text{Surface Luminance with all white pixels}}{\text{Surface Luminance with all black pixels}}$$
2. Surface luminance is the center point across the LCD surface 500mm from the surface with all pixels displaying white. For more information see FIG 1.
3. Response time is the time required for the display to transition from white to black (Rising Time, Tr) and from black to white (Falling Time, Tf). For additional information see FIG 2.
4. Viewing angle is the angle at which the contrast ratio is greater than 10. The angles are determined for the horizontal or x axis and the vertical or y axis with respect to the z axis which is normal to the LCD surface. For more information see FIG 3.

**FIG. 1 Optical Characteristic Measurement Equipment and Method**



Item	Photo detector	Field
Contrast Ratio	SR-3A	1°
Luminance		
Chromaticity		
Lum Uniformity	BM-7A	2°
Response Time		

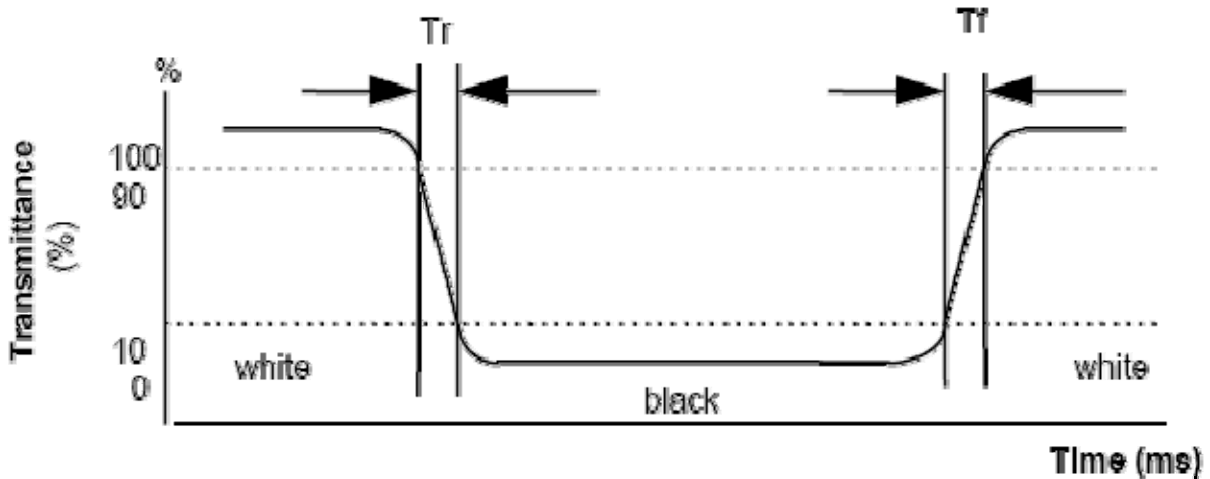


**FIG. 2 The definition of Response Time**

The response time is defined as the following figure and shall be measured by switching the input signal for “black” and “white”.

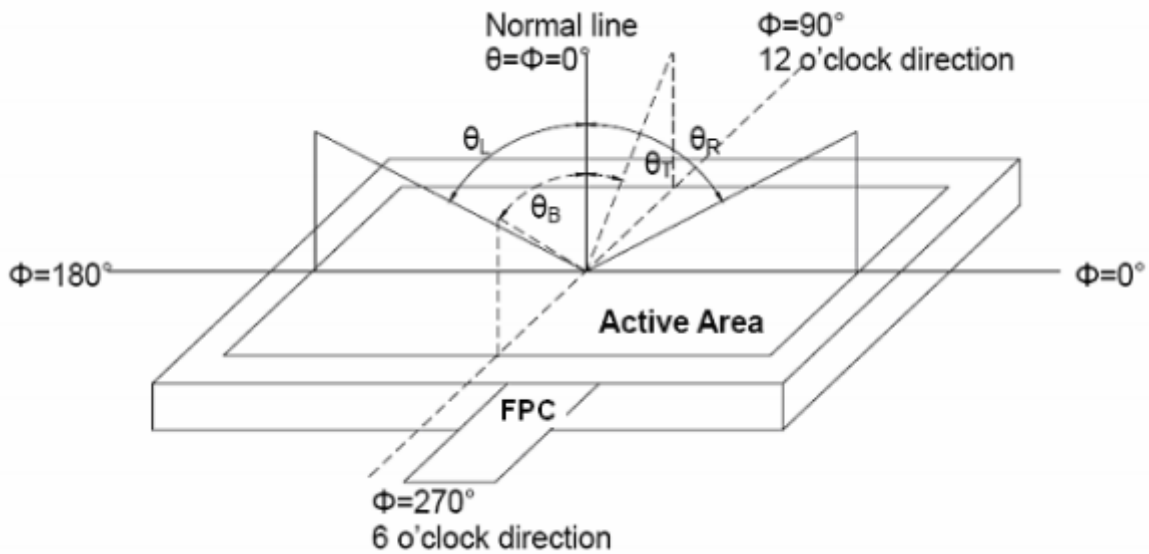
$$\text{Response Time} = \text{Rising Time}(T_r) + \text{Falling Time}(T_f)$$

- Rising Time( $T_r$ ) : Full White 90%  $\rightarrow$  Full White 10% Transmittance.
- Falling Time( $T_f$ ) : Full White 10%  $\rightarrow$  Full White 90% Transmittance.

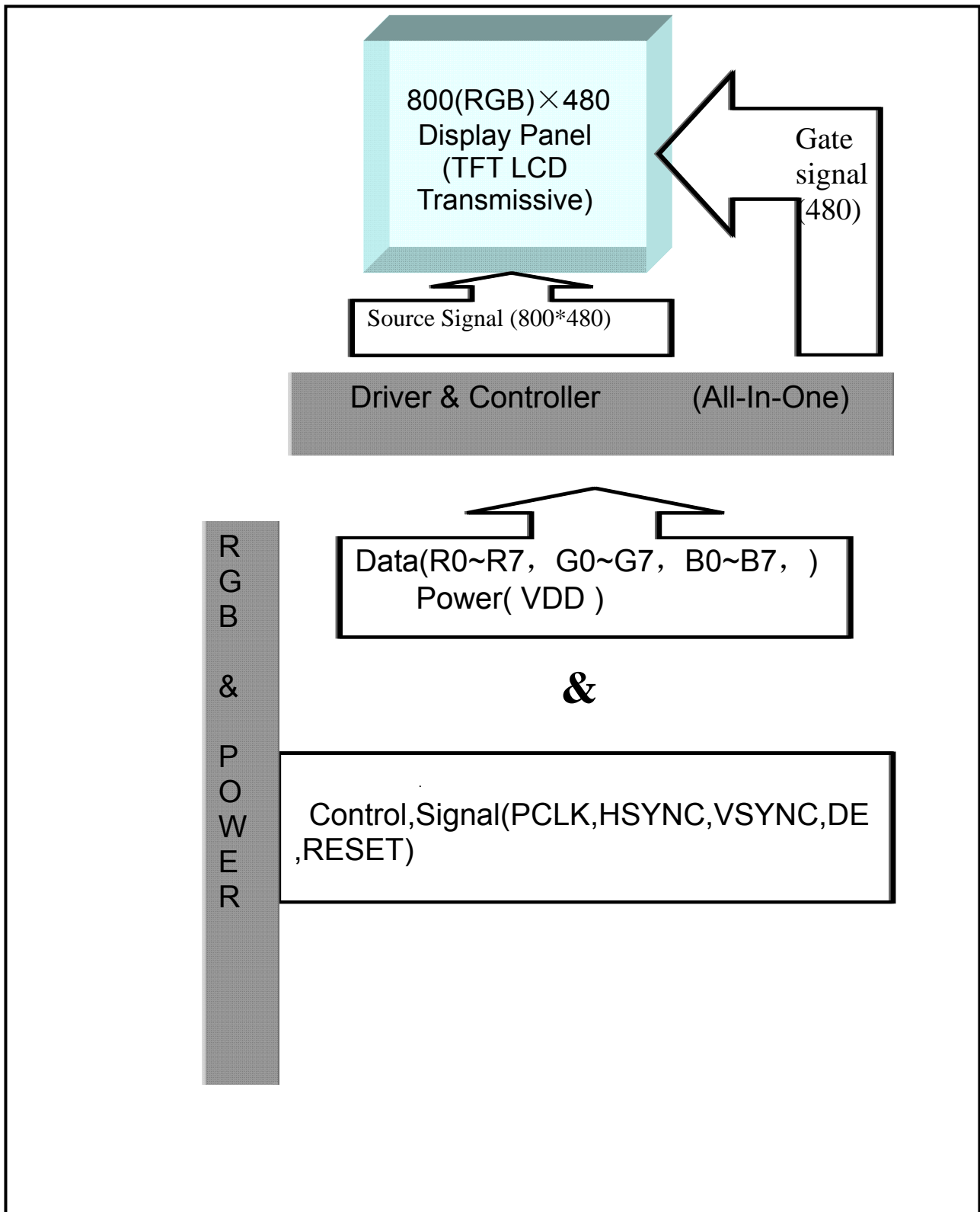


**FIG. 3 The definition of Viewing Angle**

Use Fig. 1 (Test Procedure) under Measurement System to measure the contrast from the measuring direction specified by the conditions as the following figure.



## 5. Block Diagram



## 6.Pin Description

### 6.1 TFT interface

Item	Terminal	Functions
1	VLED-	B/L Power input PIN negative
2	VLED+	B/L Power input PIN anode
3	GND	Ground
4	VDD	Power supply
5--12	R0--R7	Display for R dot
13--20	G0--G7	Display for G dot
21--28	B0--B7	Display for B dot
29	GND	Ground
30	DCLK	Clock for input data
31	DISP	Display on/off control
32	HSYNC	Horizontal synchronizing signal
33	VSYNC	Vertical synchronizing signal
34	DE	Data input enable
35	NC	No connect
36	GND	Ground
37	NC/XR	No connect
38	NC/YD	No connect
39	NC/XL	No connect
40	NC/YU	No connect

### 6.2 CTP interface

Pin	Symbol	Description
1	VDD	Working voltage 2.8V~3.3V
2	Reset	Reset
3	INT	Interrupt
4	SCL	I2C clock
5	SDA	I2C data
6	GND	GND

CTP IC driver source code will be offered separately.

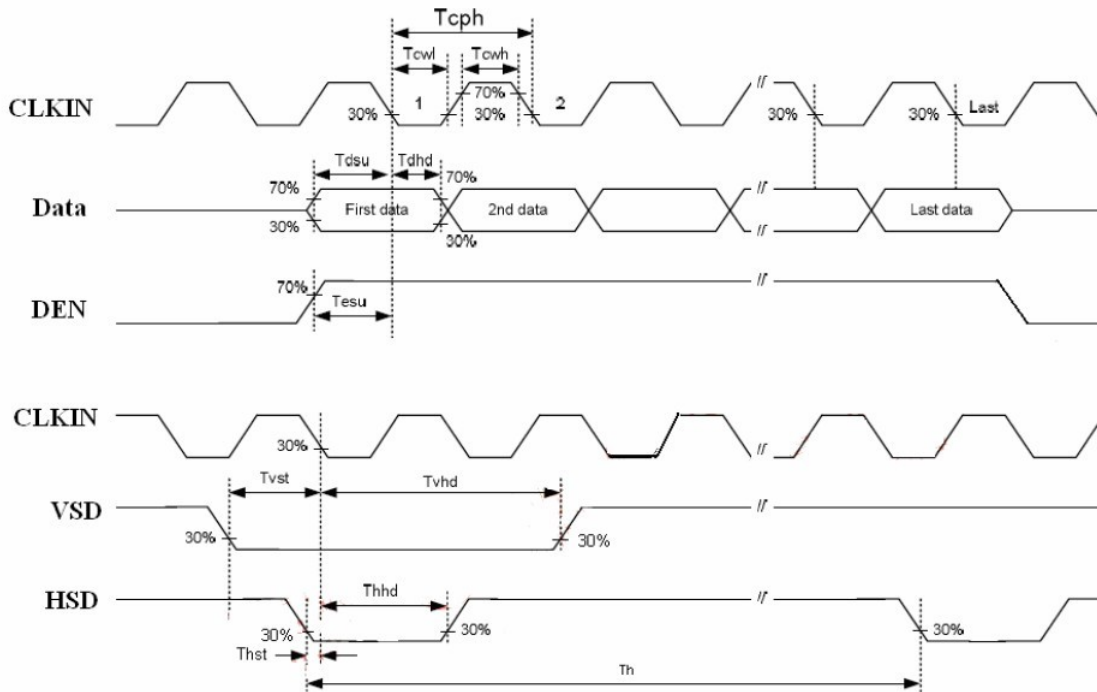
## 7. Timing Characteristics

### 7.1 Input Setup Timing setting

#### 7.1.1 Input Setup Timing setting

Parameter	Symbol	Min	Typ	Max	Unit	Remark
HSD Setup Time	$T_{hst}$	8			ns	
HSD Hold Time	$T_{hhd}$	8	-	-	ns	
VSD Setup Time	$T_{vst}$	8			ns	
VSD Hold Time	$T_{vhd}$	8	-	-	ns	
Data Setup Time	$T_{dsu}$	8			ns	
Data Hold Time	$T_{dhd}$	8	-	-	ns	
DE Setup Time	$T_{esu}$	8			ns	
DE Hold Time	$T_{ehd}$	8	-	-	ns	
CLKIN Cycle Time	$T_{cph}$	20	-	-	ns	
CLKIN Pulse Width	$T_{cwh}$	40	50	60	%	
Output stable time	$T_{sst}$	-	-	6	us	
VDD Power ON Slew rate	$T_{por}$			20	ms	
RSTB pulse width	$T_{Rst}$	10	-	-	us	

#### 7.1.2 Input Clock and Data Timing Diagram



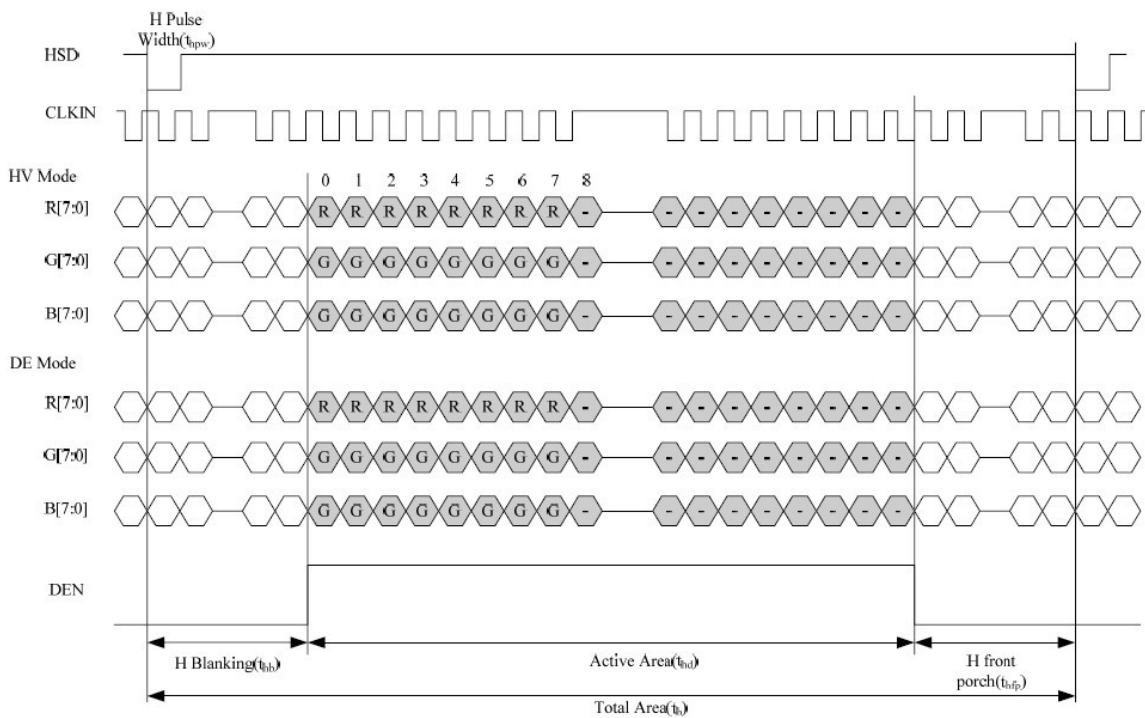
## 7.2 Data Input Format

### 7.2.1 Data Input Timing Parameter Setting

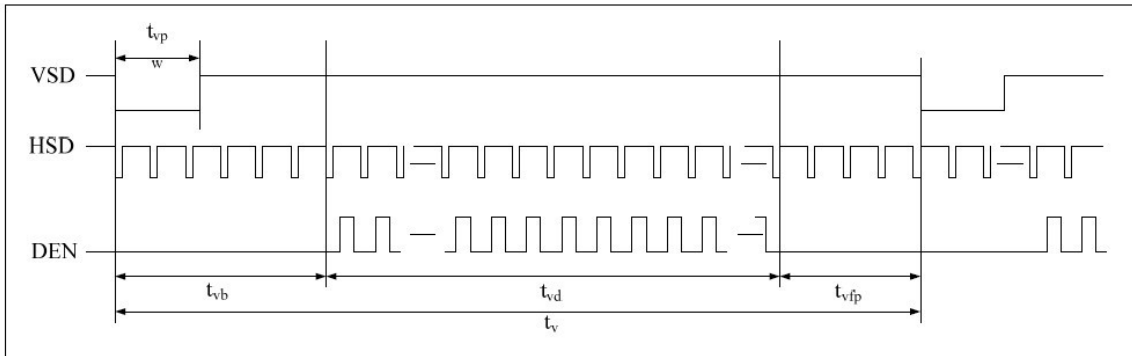
Parameter	Symbol	Spec			Unit
		Min	Typ	Max	
Horizontal display area	$t_{hd}$		800		CLKIN
CLKIN frequency (60Hz)	$f_{clk}$	-	30	50	MHZ
One Horizontal Line	$t_h$	889	928	1143	CLKIN
HSD pulse width	$t_{hpw}$	1	48	255	CLKIN
HSD blanking	$t_{hb}$		88		CLKIN
HSD front porch	$t_{hfp}$	1	40	255	CLKIN
Vertical display area	$t_{vd}$		480		$T_H$
VSD period time	$t_v$	513	525	767	$T_H$
VSD pulse width	$t_{vpw}$	3	3	255	$T_H$
VSD Blanking(tvb)	$t_{vb}$		32		$T_H$
VSD Front porch (tvfp)	$t_{vfp}$	1	13	255	$T_H$

### 7.2.2 Data Input Timing Diagram

#### 7.2.2.1 Horizontal Input Timing Diagram

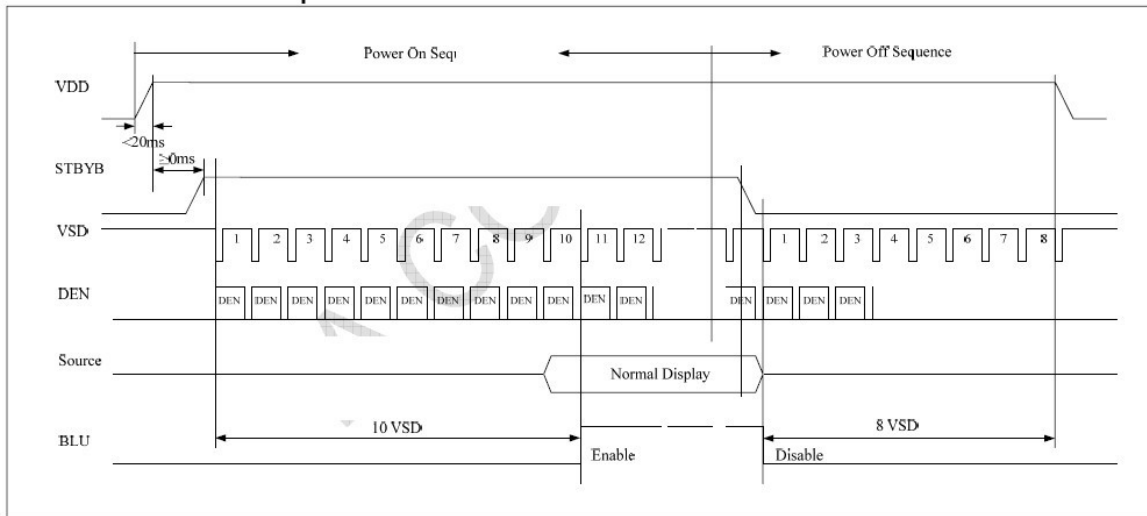


## 7.2.2.2 Vertical Input Timing Diagram

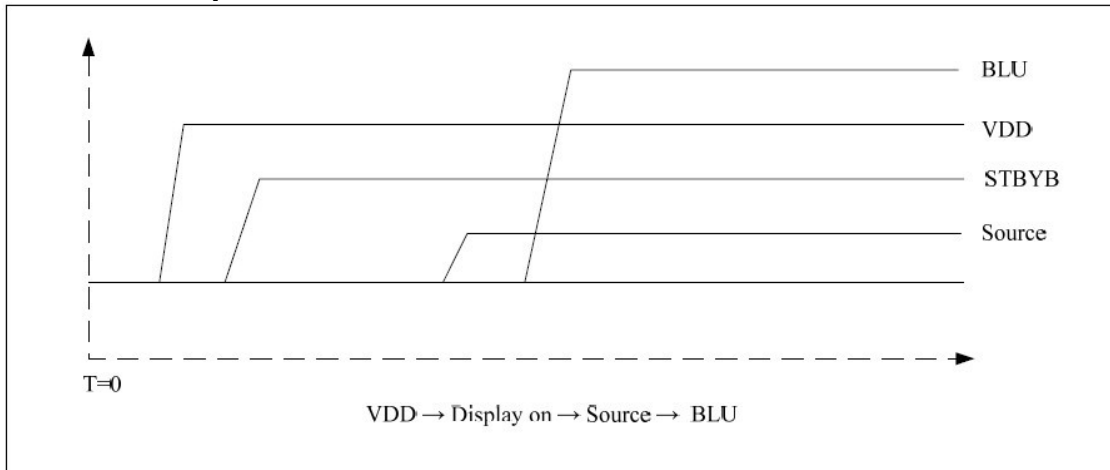


## 7.3 Power on/off Sequence

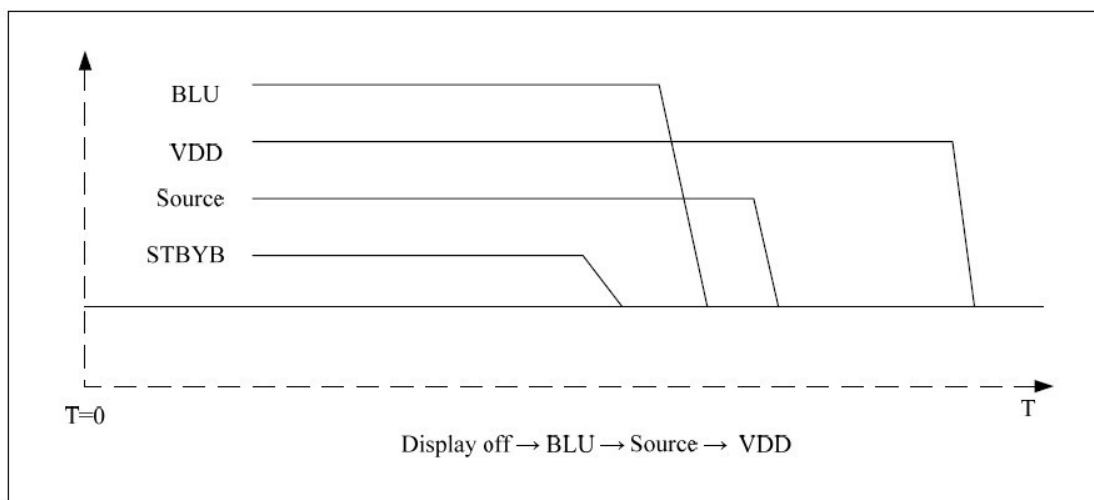
### 7.3.1 Power On/off Sequence



### 7.3.2 Power On Sequence



### 7.3.3 Power On Sequence







## 9. Reliability and Inspection Standard

No.	Test Item		Test Conditions	Remark
1	High Temperature	Storage	80℃, 120Hr	Note
		Operation	70℃, 120Hr	Note
2	Low Temperature	Storage	-30℃, 120Hr	Note
		Operation	-20℃, 120Hr	
3	High Temperature and High Humidity		40℃, 90%RH, 120Hr	Note
4	Peeling Off (Storage)		$\geq 500\text{gf/cm}$	Note
5	FPC Bending Test		$\geq 6,000$ times, 2/sec	Note
6	Vibration Test(Storage)		50HZ, 30min, Amplitude: 2 cm, X/Y/Z directions	Note
7	Drop Test		60cm/ 3Corner/ 8Face, 1Cycle	Note

Note:

- 1) The test samples should be applied to only one test item.
- 2) Sample size for each test item is 5~10pcs.
- 3) For Damp Proof Test, pure water(Resistance>1MΩ) should be used.
- 4) In case of malfunction defect caused by ESD damage, if it would be recovered to normal state after resetting, it would be judged as a good part.
- 5) EL evaluation should be excepted from reliability test with humidity and temperature: Some defects such as black spot/blemish can happen by natural chemical reaction with humidity and fluorescence EL has.
- 6) After the reliability test, the test samples should be inspected after 2 hours at least.
- 7) Functional test is OK. Missing segment, shorts, unclear segment, non display, display abnormally, liquid crystal leak are not allowed.
- 8) After testing, the current Idd should be within initial value  $\pm 20\%$ .
- 9) No low temperature bubbles ,end seal loose and fall, frame rainbow, ACF bubble growing are allowable in the appearance test.

## 10. PRECAUTIONS FOR USING LCD MODULES

### Handling Precautions

- (1) The display panel is made of glass and polarizer. As glass is fragile, it tends to become or chipped during handling especially on the edges. Please avoid dropping or jarring. Do not subject it to a mechanical shock by dropping it or impact.
- (2) If the display panel is damaged and the liquid crystal substance leaks out, be sure not to get any in your mouth. If the substance contacts your skin or clothes, wash it off using soap and water.
- (3) Do not apply excessive force to the display surface or the adjoining areas since this may cause the color tone to vary. Do not touch the display with bare hands. This will stain the display area and degraded insulation between terminals (some cosmetics are determined to the polarizer).
- (4) The polarizer covering the display surface of the LCD module is soft and easily scratched. Handle this polarizer carefully. Do not touch, push or rub the exposed polarizers with anything harder than an HB pencil lead (glass, tweezers, etc.). Do not put or attach anything on the display area to avoid leaving marks on. Condensation on the surface and contact with terminals due to cold will damage, stain or dirty the polarizer. After products are tested at low temperature they must be warmed up in a container before coming in contact with room temperature air.
- (5) If the display surface becomes contaminated, breathe on the surface and gently wipe it with a soft dry cloth. If it is heavily contaminated, moisten cloth with one of the following solvents
  - Isopropyl alcohol
  - Ethyl alcoholDo not scrub hard to avoid damaging the display surface.
- (6) Solvents other than those above-mentioned may damage the polarizer. Especially, do not use the following.
  - Water
  - Ketone
  - Aromatic solventsWipe off saliva or water drops immediately, contact with water over a long period of time may cause deformation or color fading. Avoid contacting oil and fats.
- (7) Exercise care to minimize corrosion of the electrode. Corrosion of the electrodes is accelerated by water droplets, moisture condensation or a current flow in a high-humidity environment.
- (8) Install the LCD Module by using the mounting holes. When mounting the LCD module make sure it is free of twisting, warping and distortion. In particular, do not forcibly pull or bend the I/O cable or the backlight cable.
- (9) Do not attempt to disassemble or process the LCD module.
- (10) NC terminal should be open. Do not connect anything.
- (11) If the logic circuit power is off, do not apply the input signals.
- (12) Since LCM has been assembled and adjusted with a high degree of precision, avoid applying excessive shocks to the module or making any alterations or modifications to it.
  - Do not alter, modify or change the shape of the tab on the metal frame.
  - Do not make extra holes on the printed circuit board, modify its shape or change the positions of components to be attached.
  - Do not damage or modify the pattern writing on the printed circuit board.
  - Absolutely do not modify the zebra rubber strip (conductive rubber) or heat seal

connector.

- Except for soldering the interface, do not make any alterations or modifications with a soldering iron.
- Do not drop, bend or twist LCM.

## Storage Precautions

When storing the LCD modules, the following precaution is necessary.

- (1) Store them in a sealed polyethylene bag. If properly sealed, there is no need for the dessicant.
- (2) Store them in a dark place. Do not expose to sunlight or fluorescent light, keep the temperature between 0°C and 35°C.
- (3) The polarizer surface should not come in contact with any other objects. (We advise you to store them in the container in which they were shipped).

## Others

Liquid crystals solidify under low temperature (below the storage temperature range) leading to defective orientation or the generation of air bubbles (black or white). Air bubbles may also be generated if the module is subject to a low temperature.

If the LCD modules have been operating for a long time showing the same display patterns, the display patterns may remain on the screen as ghost images and a slight contrast irregularity may also appear. A normal operating status can be regained by suspending use for some time. It should be noted that this phenomenon does not adversely affect performance reliability.

To minimize the performance degradation of the LCD modules resulting from destruction caused by static electricity etc., exercise care to avoid holding the following sections when handling the modules.

- Exposed area of the printed circuit board.
- Terminal electrode sections.